

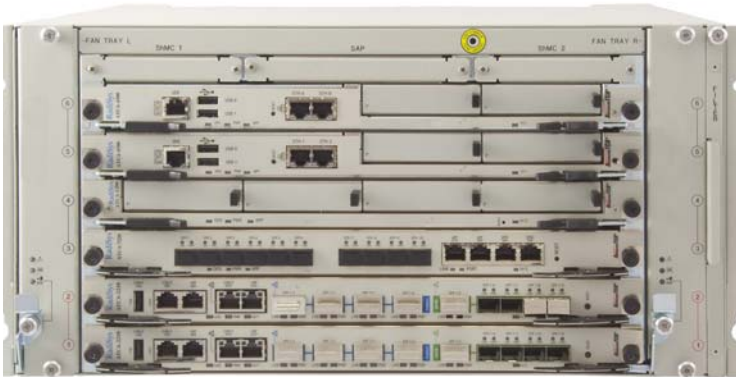

PROMENTUM™ PLATFORM INSTALLATION GUIDE

SYS-6006



This document helps you to:

Install and set up the Promentum™ SYS-6006 platform and the ATCA-6006 shelf.

Plan cable routing

Plan the implementation of the cable routing that connects the platform to equipment and the power source. The cables do not need to be available when you first install the platform, but you should know how the cables will be routed and whether they will be connected to the front or the rear of the shelf. Your choice of modules determines where connectors are located.

Obey ESD precautions

WARNING! Obey the electrostatic discharge (ESD) procedures described at www.radisys.com/esd when you install the product. Electrostatic discharge can cause permanent damage to static-sensitive components in this product. Important ESD procedures include:

- Keep the product in its ESD shielding bag until a step tells you to remove it.
- Put on a grounded wrist strap before you move near or touch the product.
- Install the product only in a grounded work area.

Prepare the installation site

Verify the installation site meets the following requirements:

- Access to the installation site and the equipment must be restricted to qualified personnel.
- A readily accessible disconnect device must be incorporated into the building's wiring between the shelf's PEM input terminals and the power source.
- The required rating of the disconnect device is determined by the nominal input voltage. See the table below for a list of permitted nominal inputs and the corresponding disconnect device ratings.

Nominal input	Disconnect device ratings
-48 V	60 VDC @ 40 A
-60 V	80 VDC @ 40 A

- The shelf requires at least 2 inches of unobstructed clearance at the side air inlets and outlets to ensure sufficient airflow for the individual blades.

- The installation site must be compatible with the recommended shelf temperatures. The shelf's maximum recommended continuous operating temperature is 40°C. The shelf is rated to operate during transient conditions from –5° to 55°C for a maximum of 96 consecutive hours. In closed or multi-rack assembly environments, the local ambient temperature may be greater than the room ambient.
- If installing the shelf in a rack, acquire the rack hardware necessary to mount the shelf. RadiSys does not supply this hardware, as different locations will require different rack hardware combinations.

Unpack the components

Important: Retain all packing materials for the shelf and for any modules and components that are packed separately. See [Shipping the platform](#) on page 7 for important information.

1. Use either an ESD wrist strap or ESD heel straps on a conductive floor surface as you open the carton.
2. Remove the ATCA-6006 shelf from its carton and place it so the slots are oriented horizontally and right side up. Use the photo of the shelf on page 1 as a guide.

The shelf houses the modules that make up the platform system. The shelf also provides power and thermal management to the modules and supports the platform's shelf management architecture.

3. Verify you have these platform FRUs and accessories, either shipped with the platform or in a separate shipping container.

Quantity	Description
1	Air filter
2	Fan trays
2	Power entry modules (PEMs)
1	ESD wrist strap
optional	Front cable guide

4. The power-feed and the ground cables are required, but not included in the package, since they are specific to the site or to the configuration.

Power-feed cable	
Wire	AWG8
Connector	Panduit LCAX8-14-L or equivalent 0.25 in (6.35 mm) hole diameter

Ground cable	
Wire	AWG8
Connector	Panduit LCD8-10A-L or equivalent Two #10 holes, 0.20 in (5.08mm) diameter 0.63 in (16.00 mm) hole spacing

5. Verify any additional FRUs and modules you ordered for your application are in the shipment:
 - Standard platform configurations include one or two switch and control modules (SCMs). The SCMs will already be installed in the shelf.
 - Rear slots will be completely populated with filler panels, except for those slots where the included front modules have companion rear transition modules installed.
 - System configurations that do not have all the front slots populated must have active modules or air management filler panels installed in them to maintain system airflow. Additional air management filler panels can be ordered separately.
6. Perform a thorough inspection of the Promentum platform to confirm components are properly installed, seated, and not loose. Pins, shrouds, mounting screws, and other items can become loose or damaged during the course of handling, shipping, and assembly. Operating a damaged platform can harm the shelf and the devices that interface to it.

Mount the shelf in a rack

The shelf can be placed on a flat surface like a table or mounted in a rack. Follow these procedures if mounting the shelf in a rack.

Prepare the rack

1. Verify the rack environment in which the equipment is being installed is compatible with the maximum transient operating temperature (55°C).
2. Confirm the rack is stable and will not tip over when the shelf is being loaded in it.
3. Support rails are recommended but not essential. Refer to the rack's documentation for information on installing the rack and any required rails.

Install the shelf

1. If the shelf is to be lifted by hand into the rack, it is recommended you remove all of the modules from the front of the shelf to reduce its weight.

If you are using equipment to lift the shelf into the rack you can skip the removal of modules and proceed to [step 3](#).

To remove modules:

- A. Loosen the thumb screws on each module and lift the ejector latches to the open position.

WARNING! Never force open an ejector latch.

If the latch does not open fully, close the latch and try again. Some modules may have different ejector latches from what appears in the example shown and may operate differently. Refer to the module documentation if you are unsure of how they work.

- B. Remove and place each module in a separate anti-static bag or on a grounded surface. Do not stack the modules on top of each other. When handling the modules, follow the ESD precautions as described on page 1.

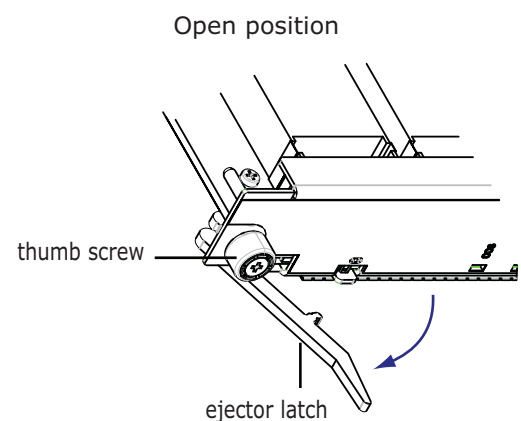

2. Employ at least two people and use safe lifting precautions to lift the shelf into the rack and slide it onto the support rails.
3. Secure the shelf to the rack by its mounting brackets. Refer to the rack's documentation for information on the appropriate hardware to use.
4. Verify the shelf is level and not twisted in the rack. Uneven mounting may cause difficulties with module installation and alignment with shelf features.

Install the front modules

1. Attach your ESD wrist strap to one of the shelf's front ESD friction-lock connectors, which are located in the top corners of the shelf. Protect the modules from ESD damage as described on page 1.
2. Slide an SCM half way into physical slot 2. For proper orientation of the SCM, verify the RadiSys logo appears on the left side of the module's front panel.
If correctly aligned, the right and the left edges of the SCM will fit within the narrow channels of the shelf.
3. To fully seat the module into the shelf:

- A. Lift the ejector latches outward to the open position, and insert the module all the way into the shelf.

WARNING! Do not force the SCM into the slot:

- To avoid damage to connectors, make sure the rear slot is either empty or contains a module that is compatible with the SCM.
- If the SCM does not slide easily, make sure you are inserting it into the correct slot and that it is aligned properly.

- B. Close the ejector latches. This will seat the module's connectors into the backplane.

4. Install the second SCM into physical slot 1, and latch it into place. Follow the same steps as for the first SCM.

If your configuration has only one SCM, install an air management filler panel into physical slot 1.

5. Install the compute processing modules, the disk storage modules, and any other front-slot modules one at a time, using the same steps you used to install the SCMs. If you have specific slot-assignment instructions, follow those instructions. Otherwise, use the slots closest to the SCMs.

If a module mates with a rear transition module, confirm the rear transition module's zone 3 connection is located at the rear of the slot before installing the module.

6. Install front and rear air management filler panels into any empty slots:
 - Do not use blank faceplates in place of filler panels. To ensure proper thermal and emissions profiles, use flow blocking filler panels.
 - Load the node slots with active modules sequentially from bottom to top and install flow-blocking filler panels in all unpopulated slots.

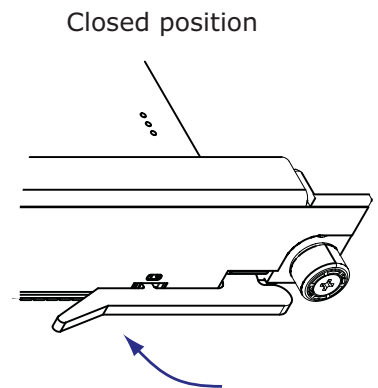

Connect frame-ground and power-feed cables

These steps cover connecting the frame-ground cables to the platform and connecting the power-feed cables to the power entry modules (PEMs) located on the back of the platform.

1. If you are wearing an ESD wrist strap, take it off. For maximum safety, keep one hand behind your back and use tools with properly insulated handles.

WARNING! Failure to follow recommendations below may cause personal injury or damage electronic equipment. An electrical voltage of up to 75 VDC may be present at any power connection.

- If you are installing an AC to DC power supply for the platform system, install it before connecting the power-feed cables. See the installation instructions included with the AC to DC power supply for more information.
 - Do not touch a power cable when power is supplied.
 - Do not place wires, screwdrivers, meter probes, oscilloscope probes, or other electrically conducting material into contact with a live power cable or anything connected to a live power cable.
 - Do not wear any watches, bracelets, or rings when working with a live power cable or anything connected to a live power cable.
 - Disconnect power from both PEMs before servicing.
2. Verify the platform's connection to the supply circuit will not overload the circuit's overcurrent and supply wiring. The supply should be capable of delivering the equipment nameplate ratings of $-48\text{V} @ 40\text{A}$ or $-60\text{V} @ 40\text{A}$.
 3. Connect a frame-ground cable to the frame-ground connections at the rear of the shelf:
 - Use a high-quality return and safety ground cable, no smaller than #8 AWG stranded for -48V .
 - Use two 10-32 x 3/8" pan head screws. The torque should be between 2.8 and 3.4 N•m (25 and 30 lbf-in).

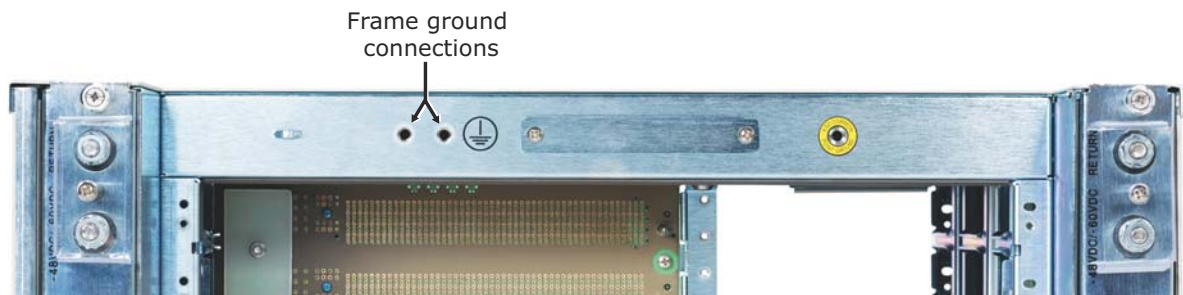

4. Connect the other end of the frame-ground cable to a high-quality facility ground connection. Do not use a power strip, connect directly to the power source.
Failure to connect the platform to a high-quality ground connection may reduce the performance and availability of the shelf and the equipment that connects to it. Improper grounding may increase electrical noise in the shelf, causing data loss and other performance degradation.
5. Switch the toggle switch circuit breakers on PEM R and PEM L to the OFF position.
6. Make sure the power-feed cables are not attached to a power source, then route two power-feed cables to the area behind the shelf, but do not yet attach them to a power connection.

7. Use a Phillips screwdriver to remove the #6 screw on the PEM's safety cover. Set the screw aside. Remove the safety cover to expose the power connectors.
8. Use a 7/16" wrench to remove the 1/4"-20 top nuts and star washers from each of the power connector posts on the PEM. Set the nuts and washers aside.
9. Connect the power-feed cables to the appropriate connectors. Check the labels next to the connectors for polarity.
10. Reattach the removed nuts and washers. Torque the nuts to 6.95 N•m (61.5 lbf-in).
11. Reattach the safety cover. Torque the safety cover screw to 0.90 N•m (8 lbf-in).
12. Turn on the power distribution to the power-feed cables.

Power up

In the following steps, a loud alarm may sound if an alarm condition occurs and the shelf has the alarm panel installed. Be prepared to insert the end of a pen or a paperclip into the pinhole labeled with the "alarm off" graphic (a bell with line through it) on the front panel to press the button. This acknowledges and silences the alarm. For additional information on the alarm panel, see the *SYS-6006 Hardware Reference* and the instructions that come with the alarm panel.



To power up the shelf:

1. One at a time, switch the PEM circuit breakers to the ON position.
2. Verify the power LEDs on the PEMs, the SCMs, and the other modules are all lit solid green. If any of the power LEDs are not lit, see the *SYS-6006 Platform Hardware Reference*.
3. Wait for any automatic boot-up actions to occur. In particular, verify the hot-swap LEDs on all the modules stop blinking. If any hot-swap LED continues to blink for more than two minutes, verify the module is properly latched. If any hot-swap LED still continues to blink, see the *Shelf Management Software Reference*.

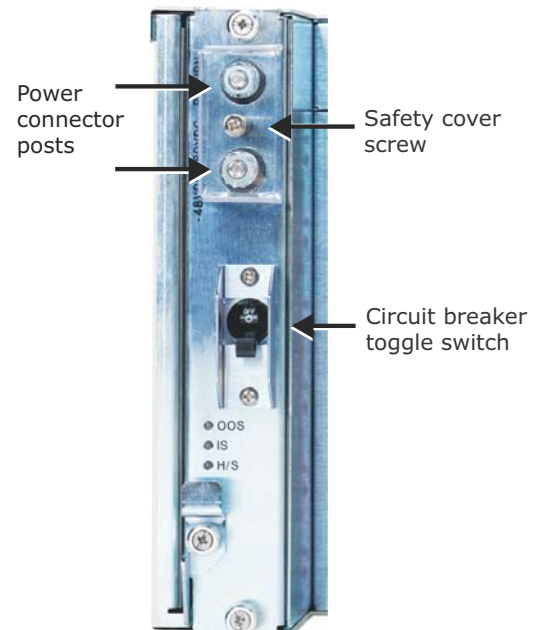

Shipping the platform

If you ship or transport the platform for any reason, it must be packaged precisely as it was shipped to you. Specifically:

- Any modules or components that were delivered in separate cartons must be removed from the shelf and repacked in their original cartons, using all original insulation and electrostatic shielding materials, prior to shipment.
- The platform must be repacked in its original carton, using all original insulation and electrostatic shielding materials.

WARNING! Failure to package the platform, modules, and components correctly for transport or shipment will void your warranty.

To purchase replacements for any of the original cartons, insulation, or electrostatic shielding materials, please contact RadiSys Technical Support.

Where to go from here

See the appropriate *Switch and Control Module Installation Guide* (ATCA-2210 or ATCA-2100) for instructions on:

- Connecting an external computer to the platform to confirm system operation.
- Verifying interaction with the platform's Base interface, Fabric interface, and shelf management software.

For an in-depth description of the platform and its hardware components, see the *SYS-6006 Platform Hardware Reference*. The shelf management components, including configuration information, are described in the *Shelf Management Software Reference*. Command line information is described in the *Command Line Interface Reference*.

Where to get more product information

Please visit the RadiSys Web site at www.radisys.com for product information and other resources. Downloads (manuals, release notes, software, etc.) are available via the Technical Support Library product links at www.radisys.com/support or the product pages at www.radisys.com/products.